

PL-1000TN

High Capacity OTU2 Optical Transport Unit



The PL-1000TN is an advanced, highly integrated 8G/10G OTU2 OTN solution with transport capacity of 60G within compact 1U

FEATURE OVERVIEW

Cost-effective, compact 1U platform with low power consumption ideal for CLE (Customer Located Equipment)

6 independent standard based Multirate OTU2 OTN transponders

Providing full OTN managed layer

Supported clients:
10G LAN/WAN, 8G/10G Fibre Channel, STM64/OC192

Supports G.Sup43 standard mappings

Three Forward Error Correction (FEC) types: GFEC, EFEC and UFEC

Supports Full C-Band Tunable DWDM Line sides

1+1 Facility uplink protection

Comprehensive Line and Service performance monitoring

Optional integrated EDFAs, Mux/Demux and/or Optical Switch modules

Remote management with In-band or Out-band Optical Supervisory Channel (OSC)

Dual AC or DC pluggable Power Supply and pluggable FAN Unit

Supports standard MSA pluggable SFP+ (client) and XFPs (uplink)

Operates on both dual fiber or single fiber solutions

UP TO 6 MULTIPROTOCOL TRANSPONDERS FOR MAPPING 8G/10G SERVICES OVER OTU2 NETWORKS

The PL-1000TN is a member of PacketLight's Optical Transport Network family. It is highly integrated solution for unified transport of different protocols such as 10G LAN/WAN, STM64/OC-192 and 8G/10G FC over common optical transport layer.

The PL-1000TN 1U device supports up to two integrated optical amplifiers and Mux/Demux providing the smallest integrated transport solution of its kind.

The PL-1000TN is designed to meet the market demands for low power consumption, rack space savings and reduction in the overall solution CAPEX and OPEX.

The OTN layer provides two additional key benefits:

- 1) Easy common management and maintenance of the optical layer infrastructure regardless of the service type.
- 2) Enhanced Forward Error Correction forming an effective ROADM based solutions.

This solution fits perfectly to the following applications:

- Transporting 8G/10G clients over long distance optical network
- Edge CPE device for end to end managed services over carrier OTN backbone Robust Packet optical network infrastructure
- ROADM based applications as Multirate OTN transponder
- Building efficient CWDM/DWDM solutions for Enterprises
- Reducing the cost of backbone solution by reducing the number of required regenerators

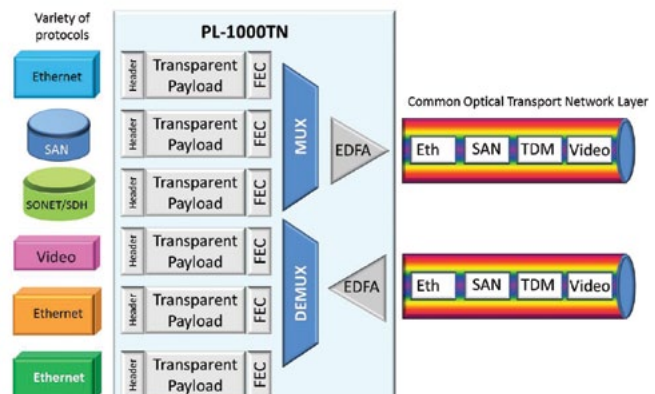

TECHNICAL SPECIFICATIONS

| System | |
|---------------------------------|---|
| Topology | Point to point, Ring, Linear Add Drop over Dual or Single Fiber |
| Transport Network Medium | Access/Metro CWDM, DWDM or Dark Fiber/Long Distance Optical fiber networks/OTN OTU2 Backbone networks |
| Protection | 1 + 1 Facility |

Product Configurations

| | |
|--|---|
| Multirate OTU2 Transponder | <ul style="list-style-type: none"> • Non APS: Up to 6 independent client signals mapped into corresponding OTU2 line protocols • APS 1+1: Up to 3 dual independent client signals mapped into corresponding 10G OTU2 line protocols |
| Multirate Transparent Transponder | <ul style="list-style-type: none"> • Non APS: Up to 6 transparent transponders • APS: Up to 3 Multirate transparent transponders |
| Multirate Regenerators | Up to 3 Multiservice clients Regenerators |
| EDFA | Up to two EDFA modules |
| Mux/Demux | Up to two Mux/Demux modules |
| Optical Switch | 1+1 APS <50Ms Switch Time Optical Module |

Optical Amplifier

| | |
|------------------------|---|
| Output Power | 14,17,20 or 23dBm |
| Input Power | -36 dBm up to 16 dBm |
| Gain | 10 dB to 22 dB |
| Operating Modes | AGC (Automatic Gain Control), APC (Automatic Power Control) |
| Eye Safety | Automatic laser power reduction upon fiber cut or disconnection |

Mux/Demux

| | |
|-----------------|------------------------------|
| Channels | 4/8/16 CWDM or DWDM Channels |
| Spacing | 50/100GHz (for DWDM) |

Line (Uplink)

| | |
|--------------------------|--|
| Protocols | <ul style="list-style-type: none"> • OTU2 (10.709) • OTU1e (11.049) as per G.Sup43 • OTU2e (11.095) as per G.Sup43 • OTU1f (11.27) • OTU2f (11.317) |
| FEC Types | <ul style="list-style-type: none"> • G.709 GFEC (RS) • G.975.1 EFEC I.4 • G.975.1 UFEC I.7 |
| Optical Interface | <ul style="list-style-type: none"> • Up to 6 Pluggable XFP transceiver • DWDM, Tunable DWDM • CWDM |

Client Service

| | |
|--------------------------|--|
| Client Protocols | <ul style="list-style-type: none"> • 10GBE LAN/WAN (10.312/9.953) • 8G/10G FC (8.5G/10.518) • STM64/OC192 (9.953) |
| Optical Interface | <ul style="list-style-type: none"> • Up to 6 Pluggable SFP+ transceiver • 850nm Multi Mode • 1310nm Single Mode |

Network Management

| | |
|--------------------------------|--|
| Ports | CONTROL, LAN, OSC, External Alarms |
| Protocols | SNMP, FTP, HTTP/HTTPS, Telnet/SSH |
| Management Applications | Web browser over HTTP/HTTPS, PacketLight NMS/EMS or 3rd party EMS over SNMP, CLI over RS-232 or CLI over Telnet/SSH |
| OAM | <ul style="list-style-type: none"> • Facility Loopback • Event Logger • Alarms • Automatic Laser Shutdown (ALS) • External Alarms |
| Performance Monitoring | <ul style="list-style-type: none"> • Intervals of Layer-1 errors, current and previous day errors. • Optical power RX/TX levels |
| Inband Management | Embedded channel in the overhead of the OTU2 uplink |
| Visual Indicators | LED status indicators for optical ports, Critical,/Major/Minor alarms, Amplifier, power supply and system |
| Software Upgrade | Traffic Hitless- dual image |

Management Ports and Physical Interfaces

| | |
|------------------------------|----------------------------|
| Control | RS-232, BD-9 |
| LAN | 10/100MBase-T, RJ-45 |
| OSC (MNG1 & MNG2) | 100 Base-FX, SFP |
| Inband Channel | Based on GCC OTN overhead |
| External Alarms | 1-Input and 1-Output, DB-9 |

Power Supply

| | |
|-----------------------|--|
| AC/DC | ~90 to ~246 VAC, -36 to -72 VDC, 70W max |
| PSU Redundancy | Single/Dual feeding, Hot Swappable |
| Cooling Unit | Hot Swappable Fan Unit |

Environmental

| | |
|------------------------------|--|
| Operating Temperature | -5° C to 55° C (+23° F to +131° F) Operational |
| Humidity | 5% to 85% RHI |

Physical Dimensions

| | |
|-----------------|---|
| Size | 1.77"(1 RU) (H) x 17.32"(W) x 9.05"(D) 45 mm(H) x 440mm (W) x 230 mm (D) |
| Weight | 5.5 Kg / 12.1 lb (Max) |
| Mounting | 19", ETSI and 23" |

Approvals & Standards

CE, FCC, RoHS, REACH
NEBS Compliant

Configuration

| | |
|-----------------------|--------------------|
| Licensed Based | 2,4,6 Transponders |
|-----------------------|--------------------|

